



## PETRIN A SPIRALE - ELECTROMECHANIQUE SPIRAL KNEADER - ELECTROMECHANICAL

**PEB40MS**



Photos non contractuelles / Photos not contractual

- 2 vitesses
- Cuve et outil inox
- Grille de protection relevable
- Capacités : Cuve = 80 L  
Farine = 25 kg  
Pâte = 40 kg
- 2 minuteries
- Passage automatique de la vitesse
- Tableau de commande électromécanique
- Transmission par courroies
- Pieds avant réglables

- 400/50Hz/3
- Puissance : 1ère vitesse = 1.5 kW

2ème vitesse = 3 kW

- Poids net : 282 kg

### Options :

- 60 Hz - Tableau électronique

- 2 speeds
- Stainless steel bowl and tools
- Stainless steel raising safety grid
- Capacity : Bowl = 80 L  
Flour = 25 kg  
Dough = 40 kg
- 2 timers
- Automatic change of operating speeds
- Electromechanic control panel
- Belt transmission
- Adjustable front feet
- Bowl reverser switch
- Possibility to rotate bowl by pulse
- 400/50Hz/3
- Power : 1st speed = 1.5 kW  
2nd speed = 3 kW
- Net weight : 282 kg

### Options :

- 60 Hz - Electronical control panel

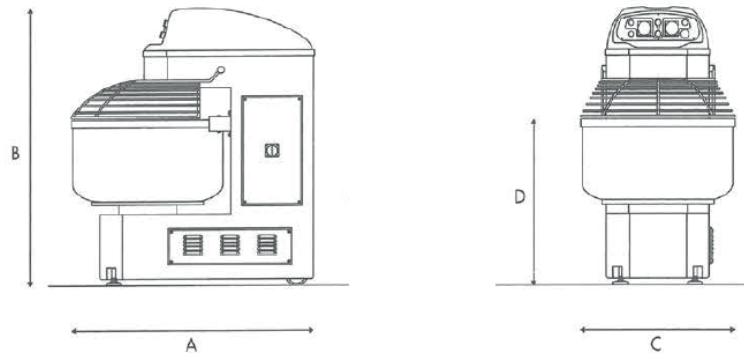

A = 1020 mm  
B = 1250 mm  
C = 550 mm  
D = - mm