



## PETRINS A BRAS OBLIQUE - AUTOMATIQUE SLANTING ARM KNEADERS - AUTOMATIC

**PAF160MA**

Photos non contractuelles / Photos not contractual



- 2 vitesses
- Tableau de commande électromécanique
- Grille de protection relevable
- Capacités : Coulage = 60 L  
Farine = 120 kg  
Pâte = 160 kg
- Cuve inox libre
- Fourche en aluminium alimentaire
- Frein de cuve
- Passage automatique de la 1ère à la 2ème vitesse
  
- 400/50Hz/3
- Puissance : 1ère vitesse = 3 kW  
2ème vitesse = 4.5 kW
- Poids net : 500 kg

### Options :

- 60 Hz

- 2 speeds
- Electromechanical control panel
- Lifiable protection grid
- Capacity : Bowl = 60 L  
Flour = 120 kg  
Dough = 160 kg
- Stainless steel free bowl
- Aluminium fork
- Bowl brake
- Automatic transition from 1st to 2nd speed
  
- 400/50Hz/3
- Power : 1st speed = 3 kW  
2nd speed = 4.5 kW
- Net weight : 500 kg

### Options :

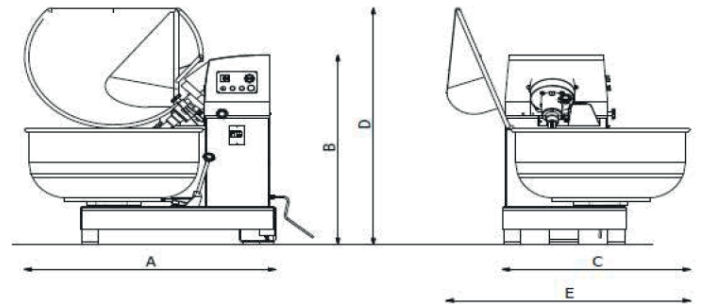

A = 1500 mm  
B = 1320 mm  
C = 1100 mm  
D = 1650 mm  
E = 1430 mm

